



9010 BT

V05

V02

## Scorrevoli su binario

Grigliato in alluminio, scorrevole su apposito sistema registrabile in altezza, completo di fermi. Griglia in alluminio da 76 x 35 mm. Guide di scorrimento inferiori con sistema antivibrante.

## On rail sliding

Aluminium grild with a specific sliding system and height regulation with locks. Aluminium grid mm. 76 x 35. Bottom rails with antivibrating system.

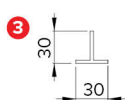
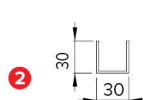
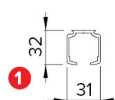
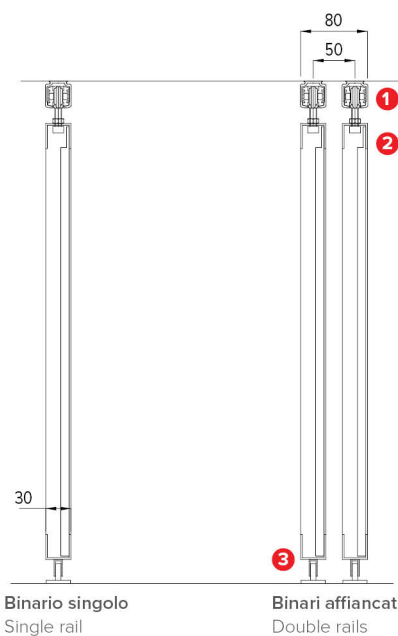
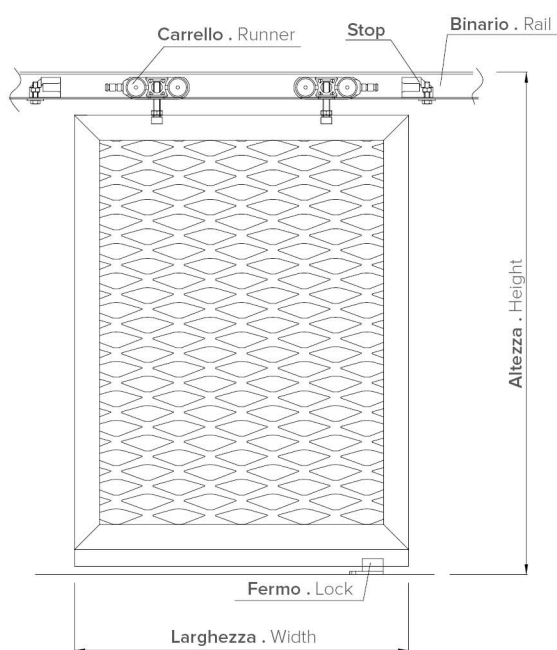
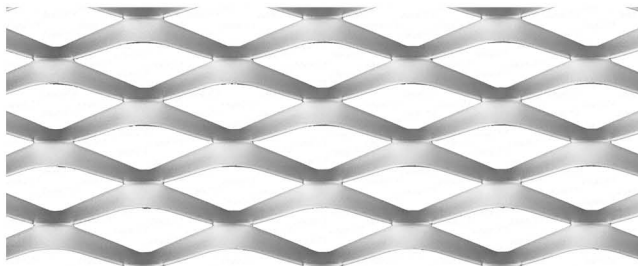

Binario inferiore per lo scorrimento del telaio  
Inferior rail for frame sliding

**1 Binario superiore. 2 Profilo portante. 3 Binario inferiore.**  
1 Top rail. 2 Main profile. 3 Bottom rail.